

PUMA MANUAL SWING BARRIER

INSTALLATION INSTRUCTIONS

1. Position the hinge post in the centre of its concrete plinth. Drill and fix 1 rear bolt using a M16 X 100mm anchor bolt.
2. Assemble the barrier frame to the hinge post by locating the bottom pin in the base plate and fixing the adjustable top hinge with the pin and clip.
3. Position the receiving post central of its plinth and support the barrier frame across the opening.
4. Align the barrier frame using the adjustable hinge.
5. When all align and square with the roadway (using shims if required) fix the remaining 3 No. anchor bolts in the hinge post base plate.
6. Shim and fix the receiving post using 4 No. M12 X 100mm anchor bolts.
7. Fit the boom signs central to the opening using fixing kit supplied (5mm pop rivets into the frame using self tapping screws).
8. Cut the boom back to the required length and fit the end cap.

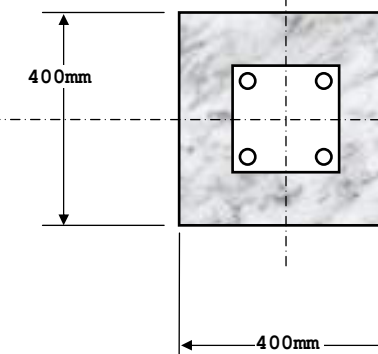
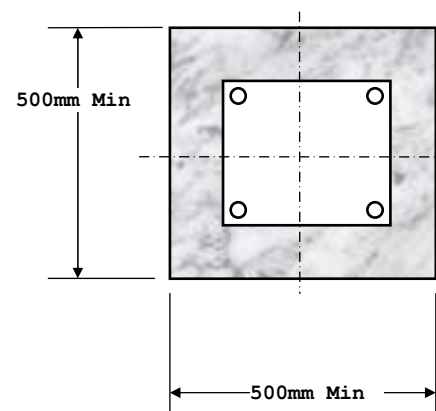

Drawn By: DSP	Date: 3rd Dec. 2001	Motivation (Traffic Control) Limited Unit 5, Horton Court, Hortonwood 50 Telford, Shropshire. TF1 7XZ Tel:01952 670390, Fax:01952 670379 Web: http://www.motivation-tc.co.uk Email: info@motivation-tc.co.uk
Client:		
Title: Puma Manual Swing Barrier.		Drawing: pumdrgr