

Boom Length 7000mm Maximum

Boom Length 6000mm Maximum, with folding skirt

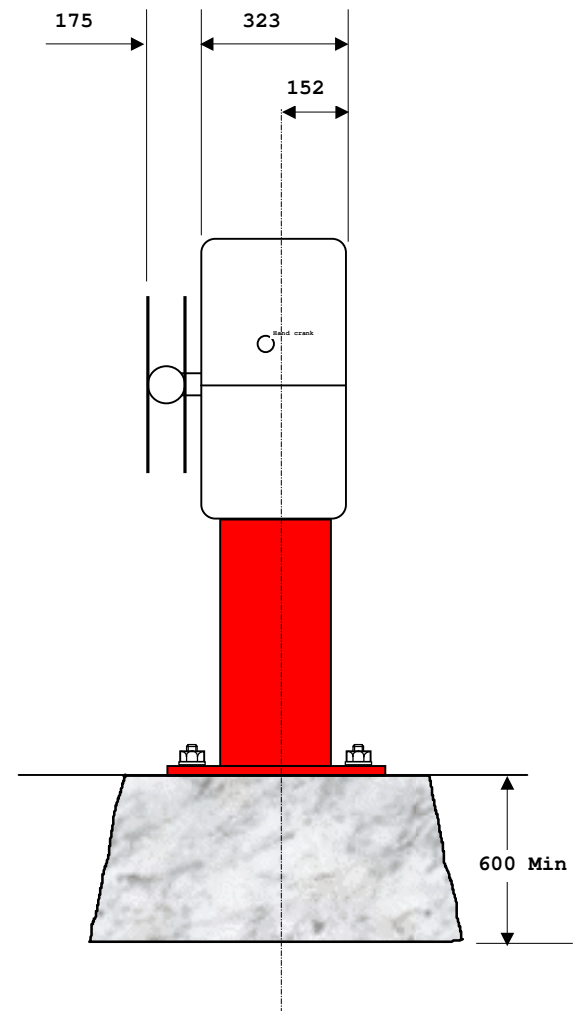

PLINTH LAYOUT:

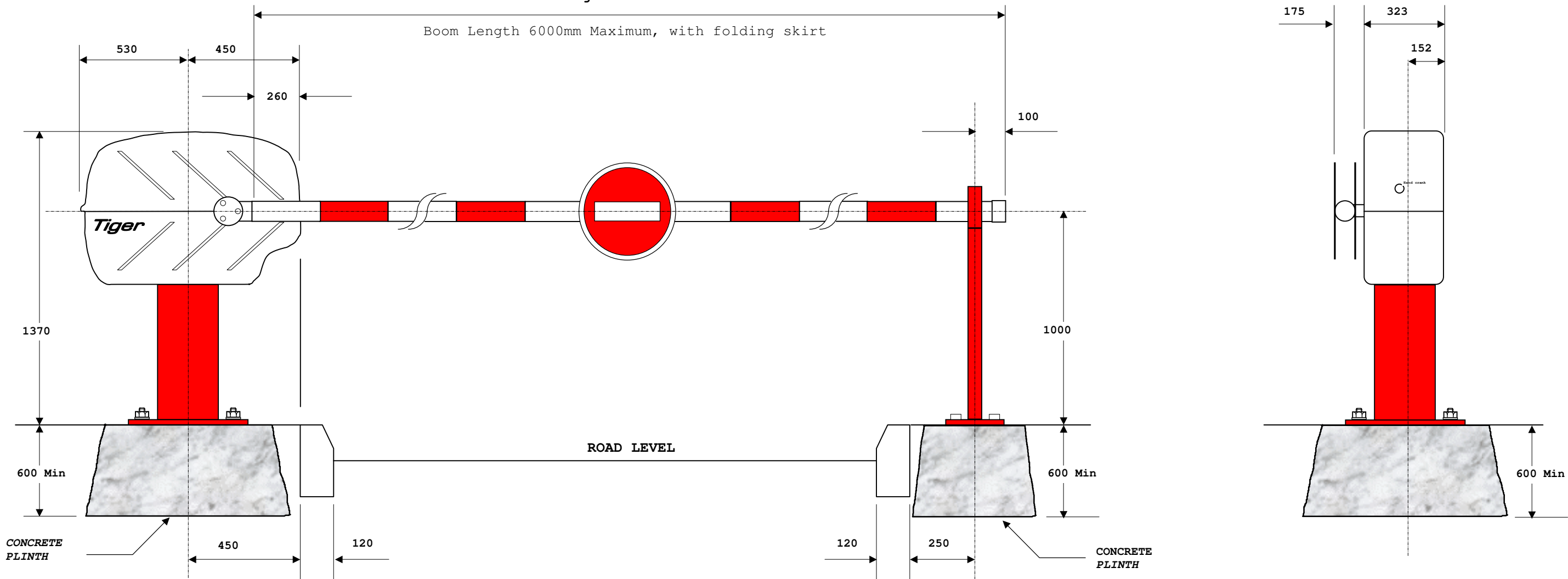
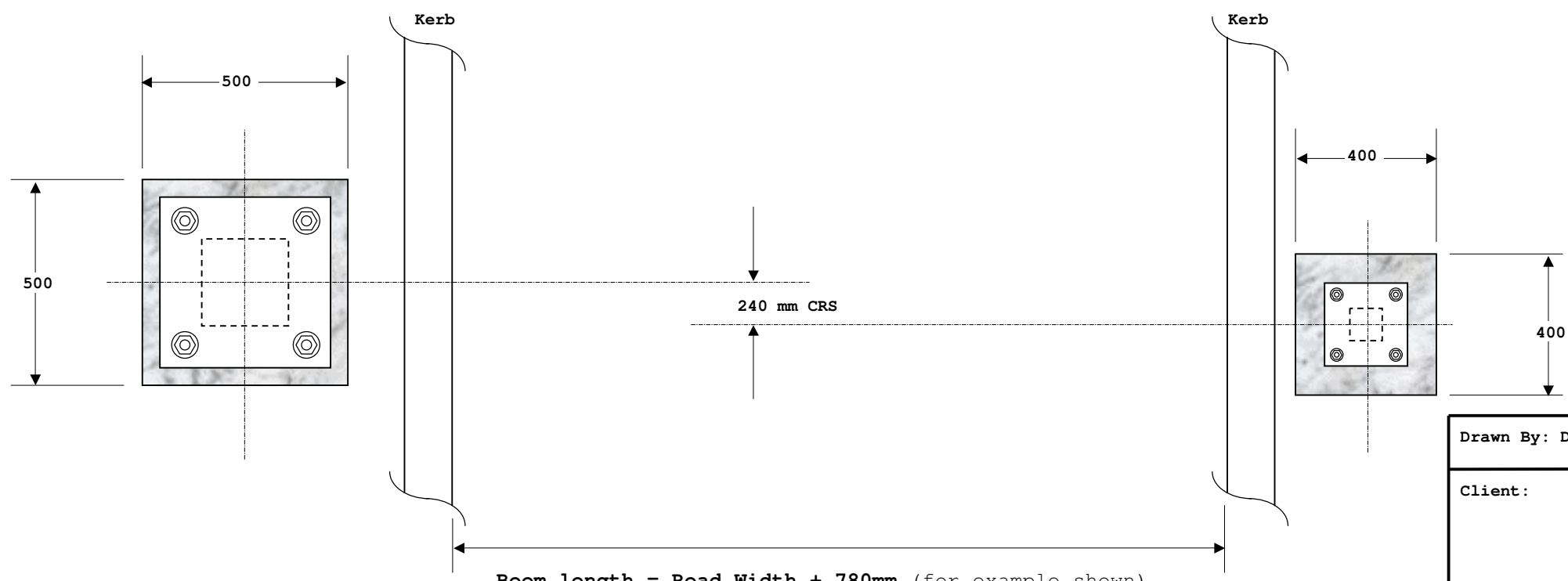

- NOTES**
- Plinth dimensions are offered as guidance only.
 - Motivation (Traffic Control) Limited are not structural engineers and that any recommendations relating to preparatory work, are based upon the practicalities of installing the Company's products.
 - Where the company may issue any verbal or written approval for such work does not imply our acceptance of any responsibility for its structural or technical suitability.

Drawn By: DSP	Date: 5/10/02	Motivation (Traffic Control) Limited Unit 5, Horton Court, Hortonwood 50 Telford, Shropshire. TF1 7XZ Tel: 01952 670390, Fax: 01952 670379 Web: http://www.motivation-tc.co.uk Email: info@motivation-tc.co.uk
Client:		
Title: Tiger Barrier General		Drawing: tigdryg